

DWK 6055 Vibration proof thermocouple

Design

Designed for use on combustion engines

Protection tube

Construction	Barstock drilled
Material	SS 316 - (Wst 1.4401)
Insertion length "L"	Customer to specify, standard 150 mm
Diameter	Conical 18 to 12 mm
Process connection	1/2" BSP
Extention length "X"	Standard 50 mm
System	Springloaded insert

Lead wire

Heat and oil resistant armoured extension cable 250°C

Lead wire length "K"

Customer to specify, standard 1000mm

Thermocouple

Sensor	K, J or L thermocouple, Customer to specify
Accuracy	According IEC 584-1
Hot junction	Insulated
Testing	Tested 500 Volt @ 20°C
Insulation	Minimum 100Mohm
Design	Vibrationproof

Temperature

800°C maximum

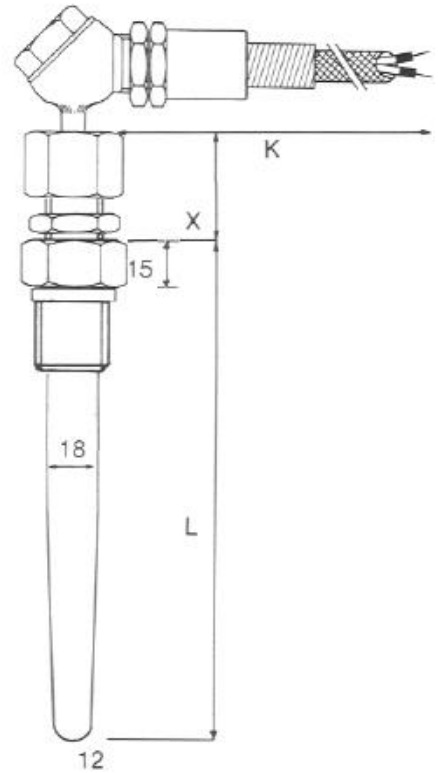

Ordering code

*This datasheet is purely indicative, build-up of model code may vary from this datasheet.

Model	DWK 6055				
Calibration					
Length "K" in mm					
Length "L" in mm					
Length "X" in mm					

H6-1 Rev. 07/07