

HT 4068 High temperature thermocouple up to 1800°C with Silicium Carbide (SiC) protection tube

Protection tube	
Construction	Gastight
Insertion length	Customer to specify
Diameter	26x4mm
Material	RSiC recrystallized Siliciumcarbide (Halsic-R)
Process connection	Sliding flange model MFA-C (showed), other executions possible for example a welded ANSI or DIN flange
Temperature range	1800°C maximum (0.5mm wires type B) 1600°C maximum (0.35mm type B wires or 0.5mm wires type R/S) 1350°C maximum (0.35mm wires type R and S)
Inner tube	
Inner tube	Gastight ceramic 710 (C799)
Connection head	
Material	Aluminium or Stainless Steel
Cable entry	M20x1.5 standard, other threads possible
Extension	
Material	Steel standard, other materials possible
Diameter	32mm standard, other diameters possible
Length	200mm standard, other lengths possible
Measuring insert	
Insulation	Ceramic rod
Calibration	B, R or S
For duplex	BB, RR or SS
Wire size	0.35 or 0.5 mm
Accuracy	According IEC 60584-1
Options	
Swing-Cover head	DAN, transmitter direct mounted on measuring insert
High Swing-Cover head	DAN-H, transmitter in cover, insert with ceramic block

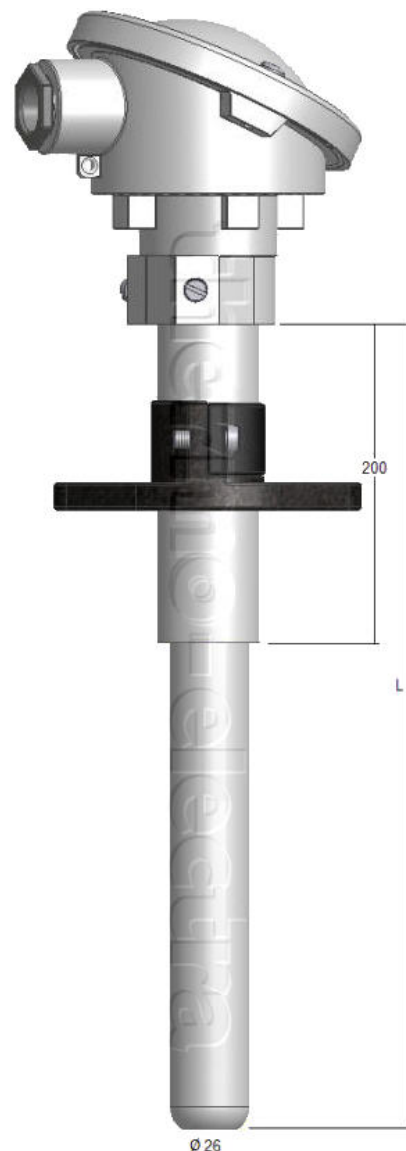

Ordering code

*This datasheet is purely indicative, build-up of model code may vary from this datasheet.

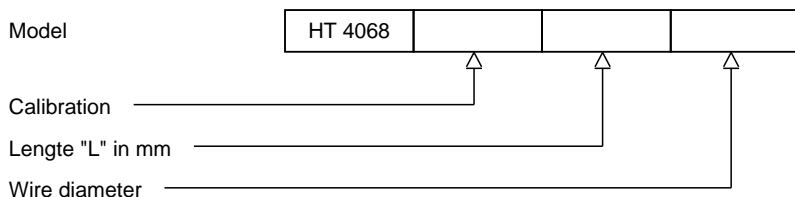

H4-1 Rev. 07/07